

# Initel Telecomponents

**Via degli Ulivi3 - Zona Ind.**

**74020 Montemesola (TA) Italy**

**Email:info@telecomponents.com**

**www.telecomponents.com**

**Phone: +39 3929784631**

# Broadcast Information

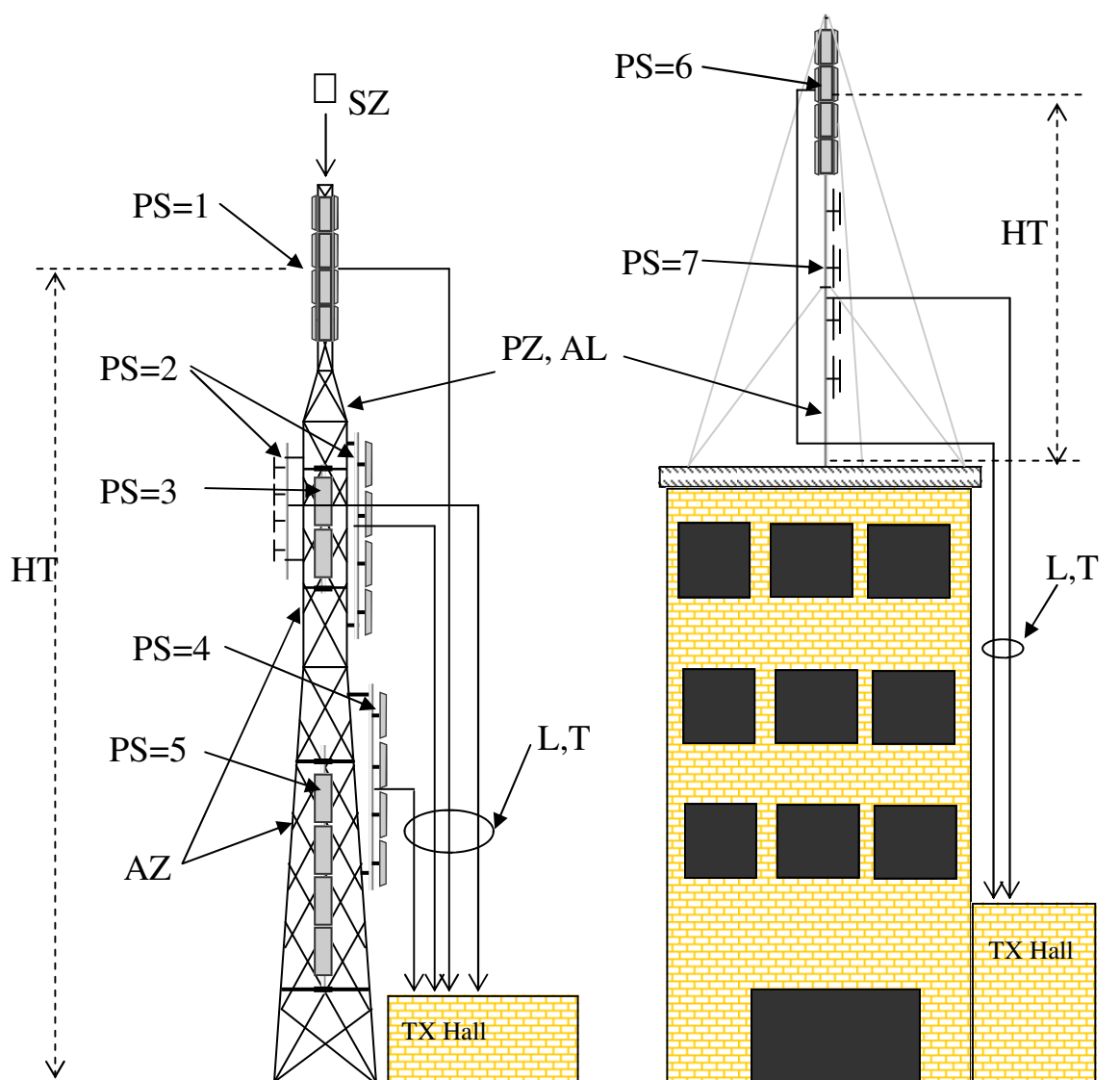

PS= Antenna position:  
 1= Tower: On Top  
 2= Tower: Installation on straight angular  
 3= Tower: Installation on side straight  
 4= Tower: Installation on angular trapezoidal section  
 5= Tower: Installation on trapezoidal side  
 6= Pole: On Top;  
 7= Pole: On the side  
 8= Others configuration (to explain)

Informations table		
Feeder Cable Length (meters)	L	
Feeder Cable type	T	
Mast Diameter (cm)	PZ	
Tower or Mast diameters (cm)	AL	
Angular size relating to the mounting point of the brackets (cm)	AZ	
Turret size (side x side)(cm)	SZ	
Antenna position (1,2,3,4,5,6,7,8)	PS	
Height of antenna center from the tower or pole base (meters)	HT	

# Telecomponents

Coverage Area (Km)

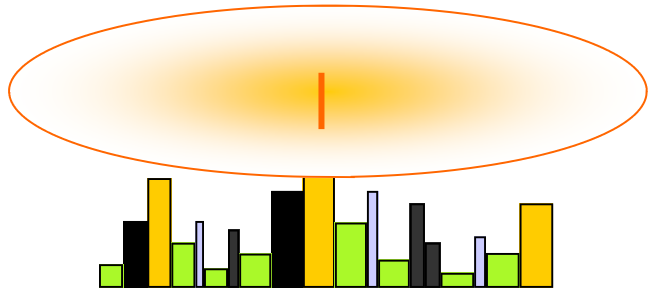

Type 1 Site

Coverage Area (Km)

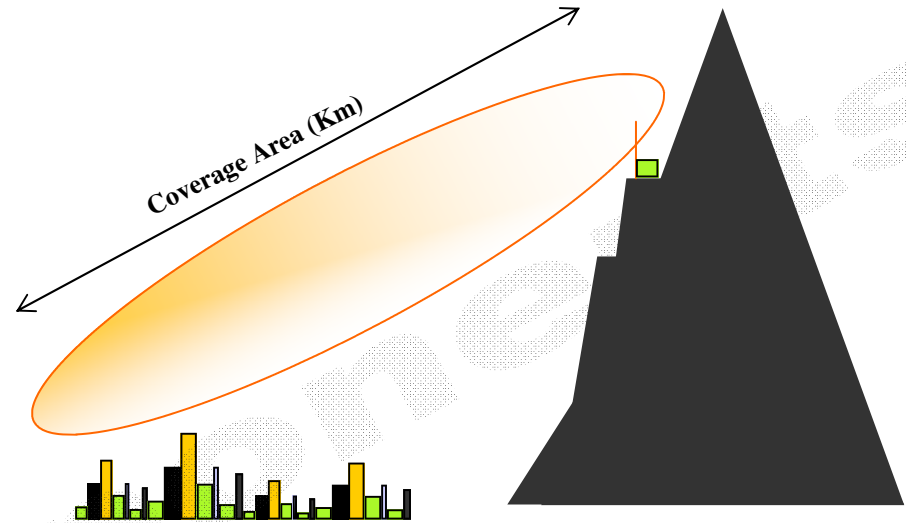

Type 2 Site

Coverage Area (Km)

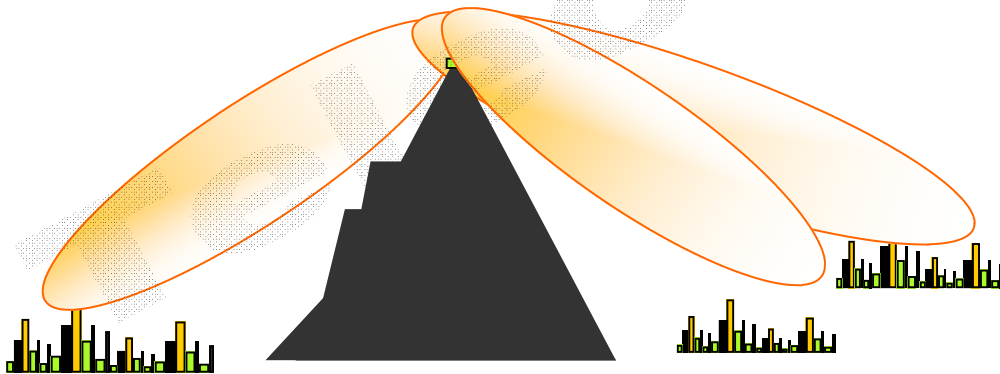

Type 3 Site

Coverage Area (Km)

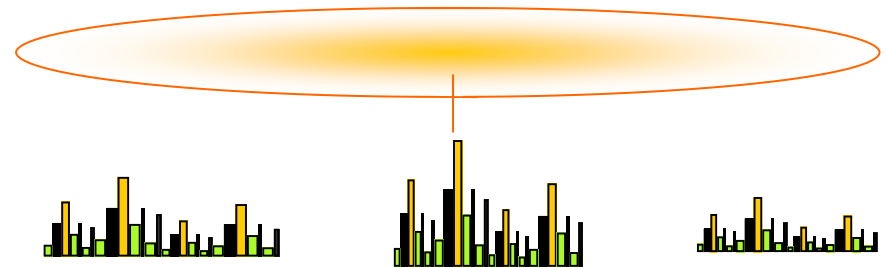

Type 4 Site

4 PANELS

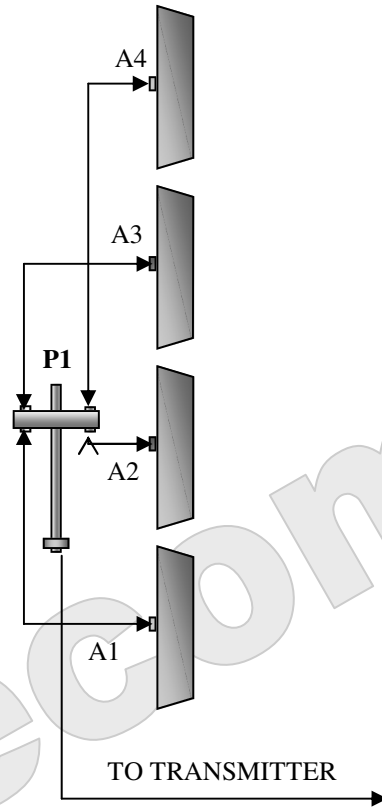
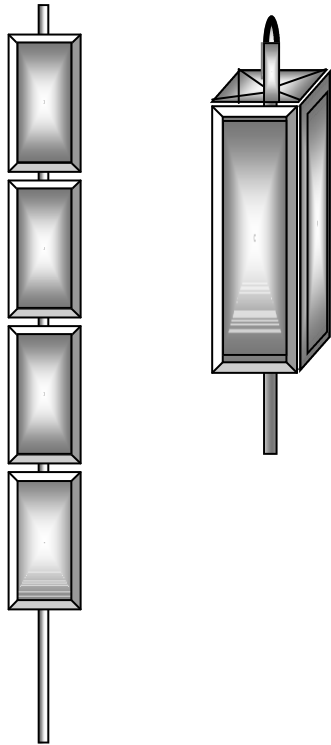

Configurations:  
 1+1+1+1  
 1+2+1  
 2+2  
 4 inline

8 PANELS

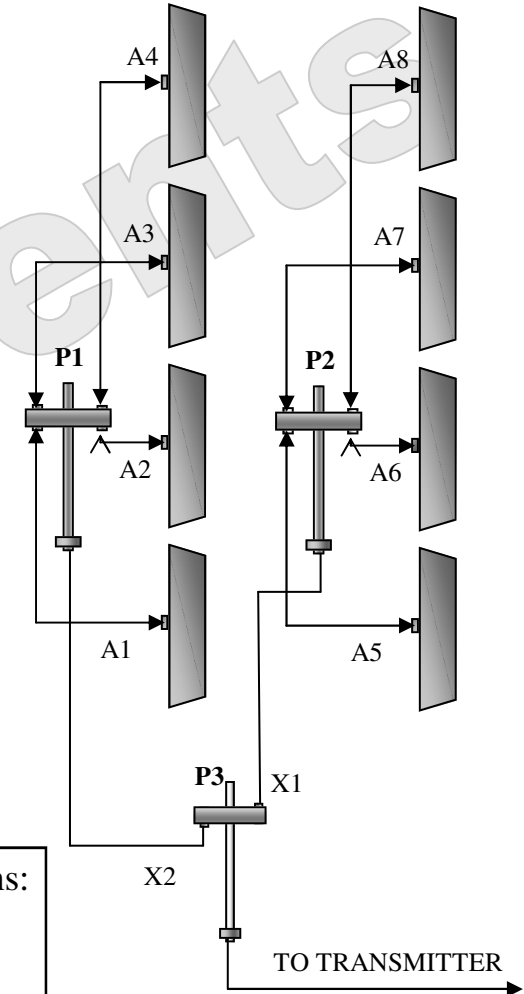
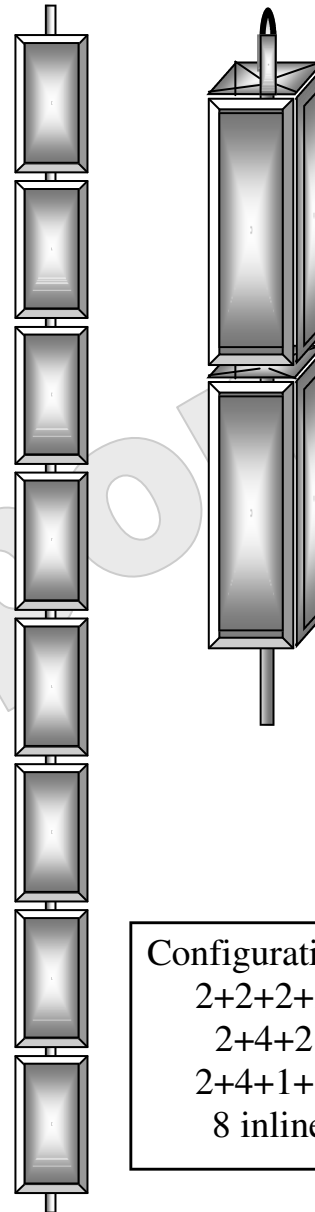

Configurations:  
 2+2+2+2  
 2+4+2  
 2+4+1+1  
 8 inline

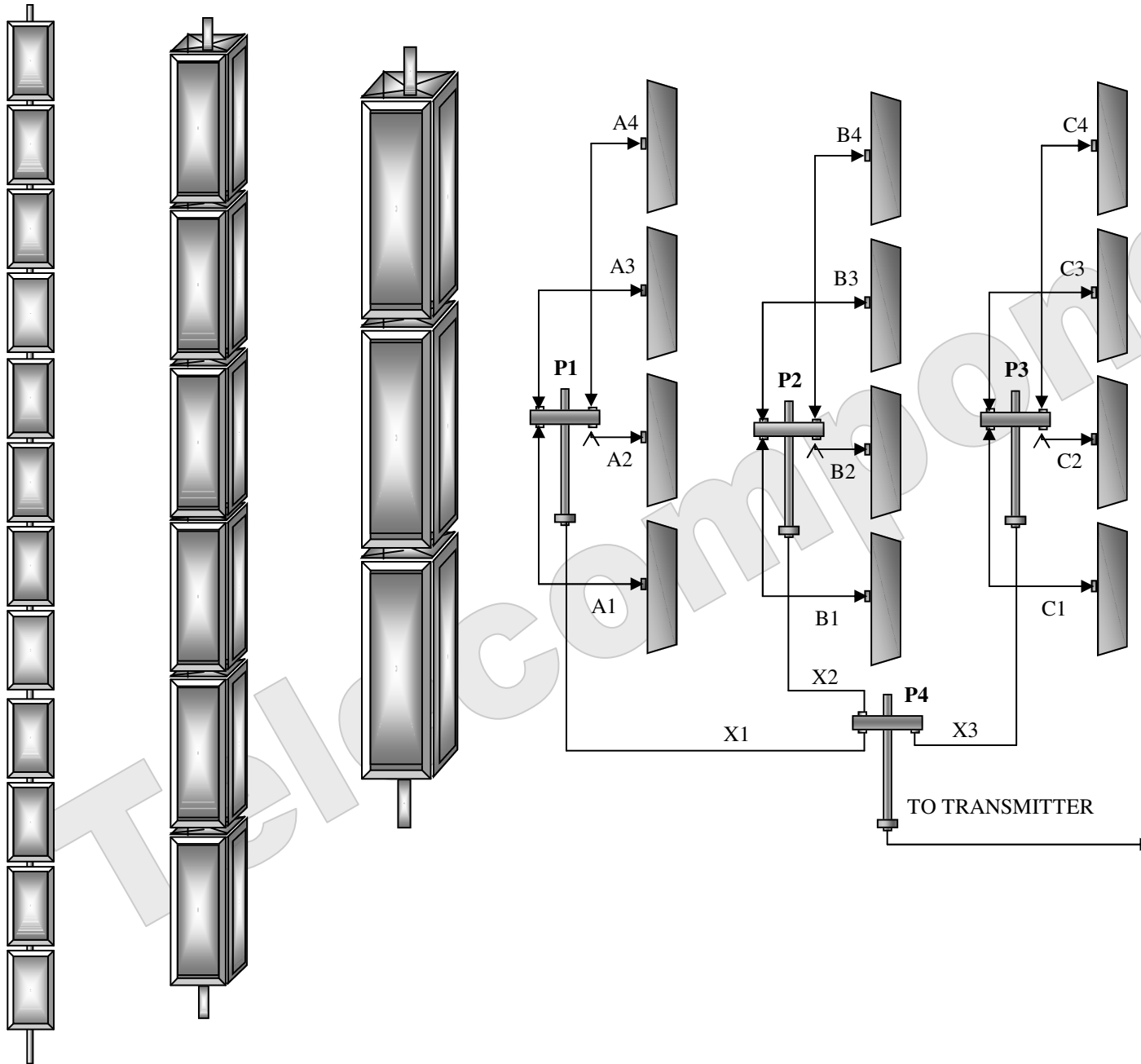

Configurations:  
6+6  
3+6+3  
3+3+3+3  
12 Inline

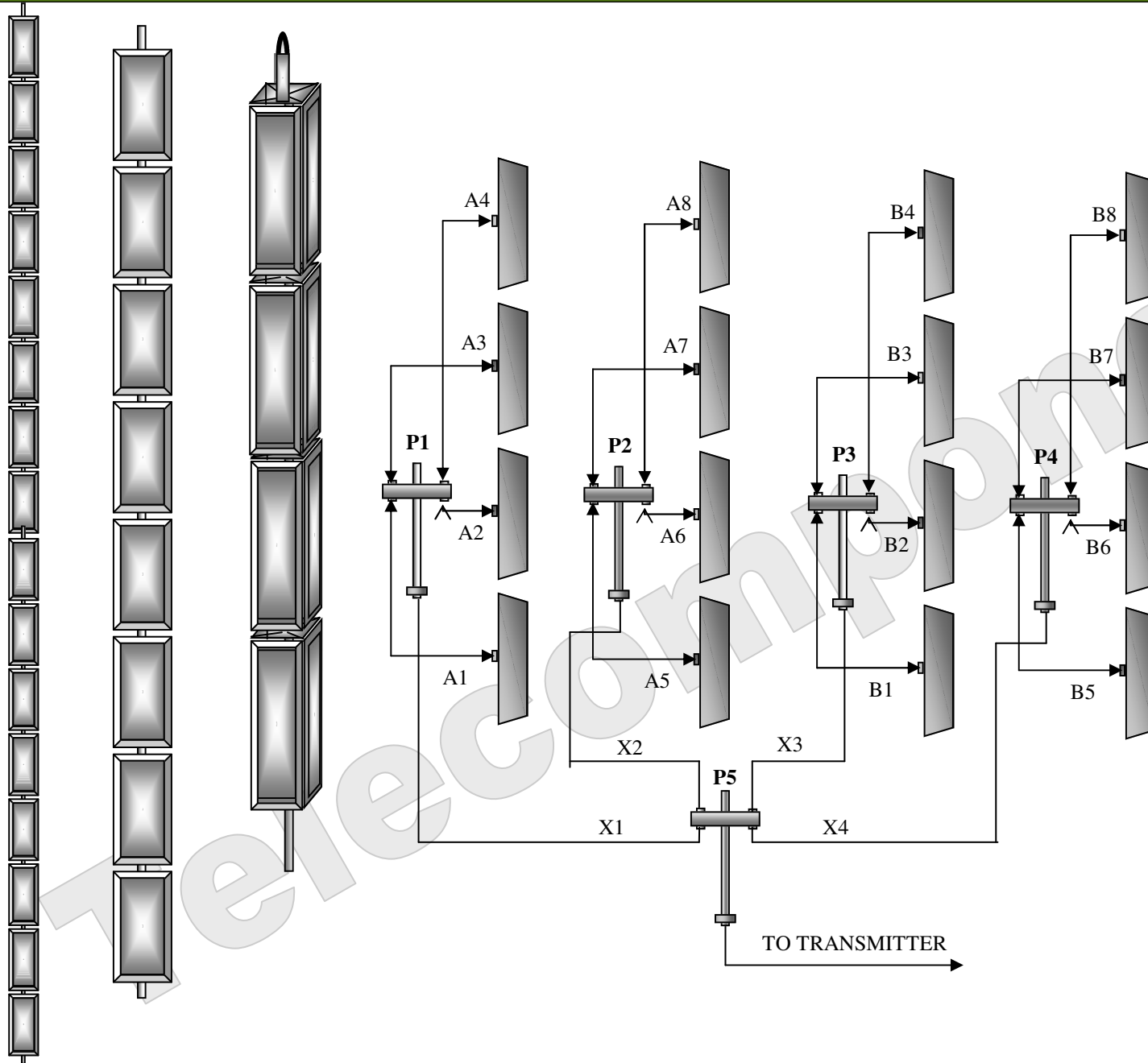

- Configurations:**
- 8+8
  - 4+4+4+4
  - 4+8+4
  - 2+12+2
  - 16 Inline

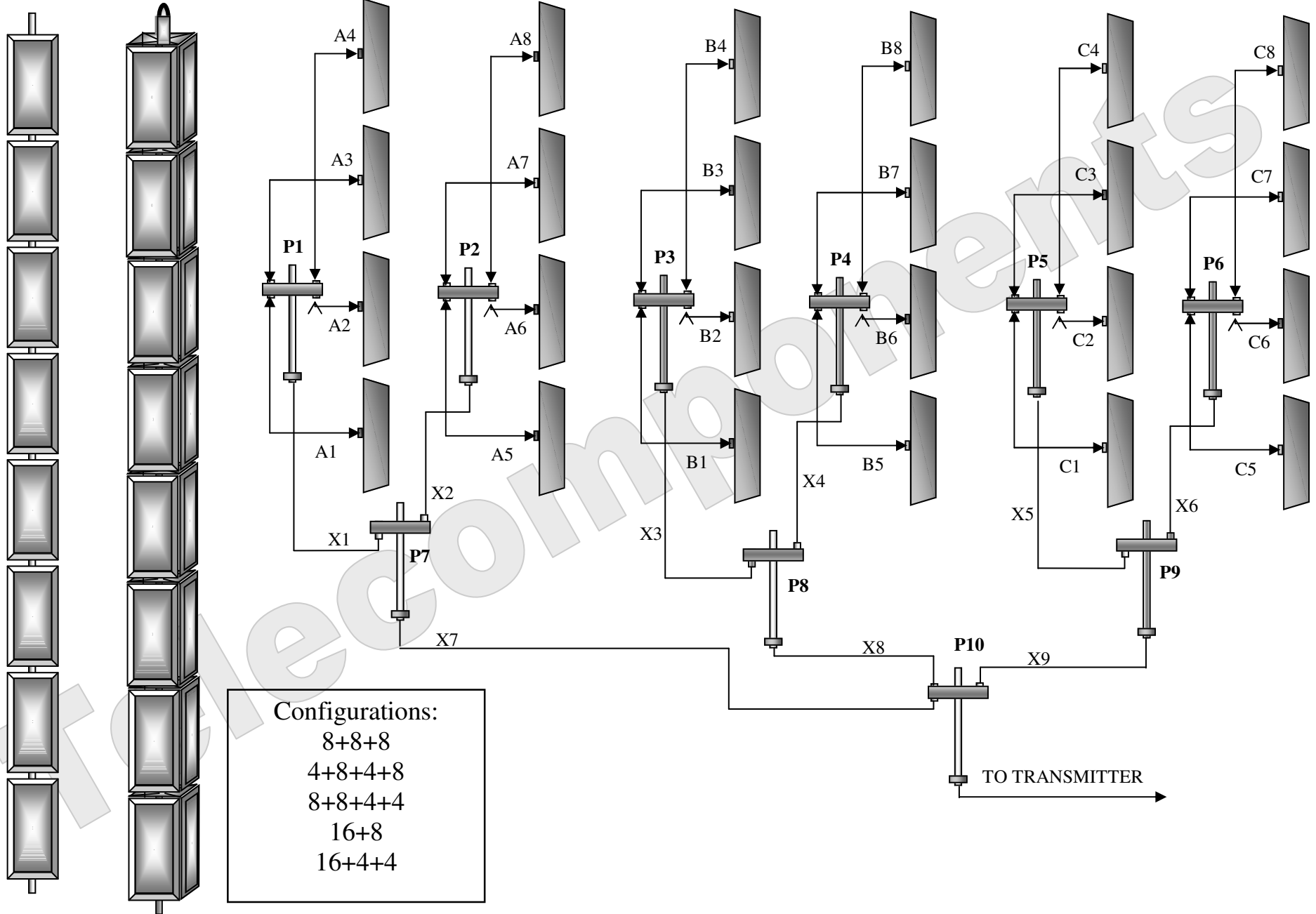

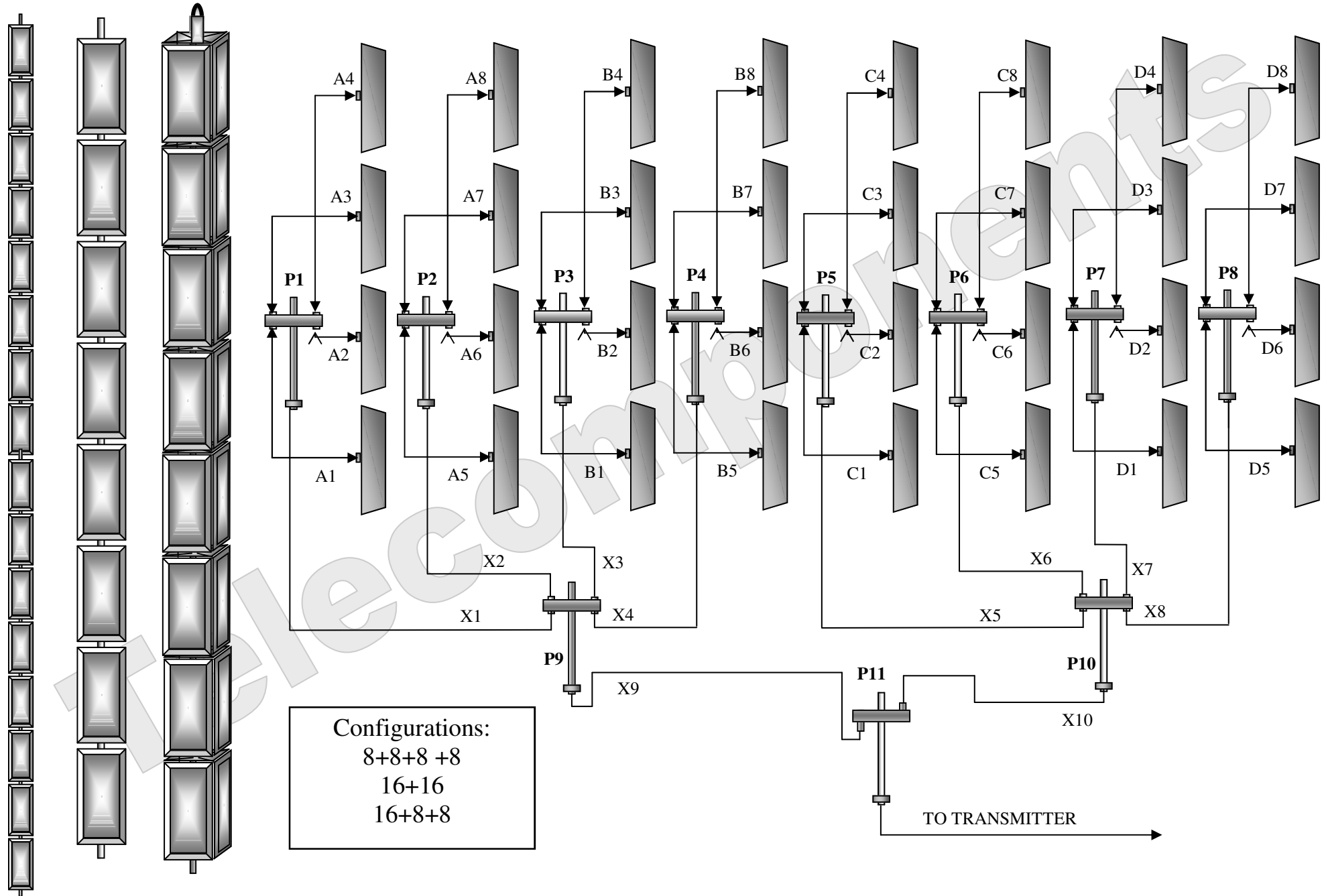

Configurations:  
 8+8+8 +8  
 16+16  
 16+8+8





SMA  
MALE

SMA

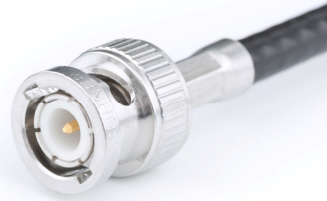

BNC



PL1259

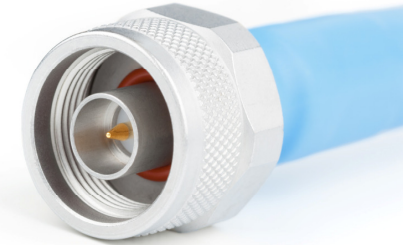

N



7/16" DIN

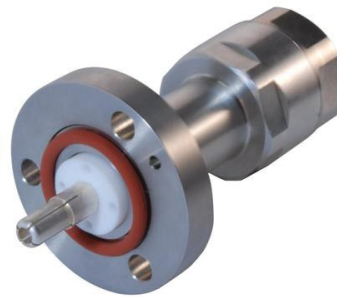

7/8" EIA



1 5/8" EIA



3 1/8" EIA



ANDREW CABLES AIR DIELECTRIC

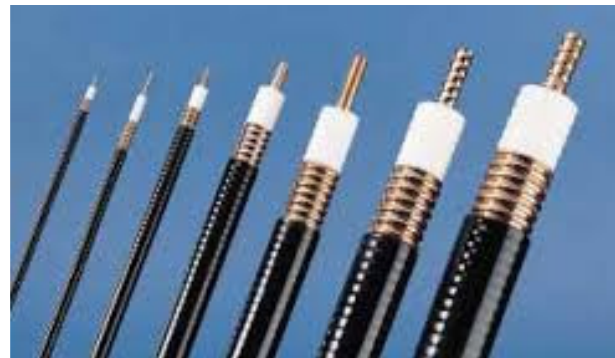

ANDREW CABLES FOAM



RG CABLES

# Telecomponents

**COAXIAL CABLES POWER WORK (kW)**  
**AIR DIELECTRIC** **FOAM DIELECTRIC**

Mhz	1/2"	7/8"	1" 5/8	Mhz	1/2"	7/8"	1" 5/8	Mhz	1/4"	1/4" Superflex	1/2"	1/2" Superflex	3/8"	7/8"	1" 5/8
0,5	10	54	180	0,5	7	29	98	0,5	6,9	4	22	7,5	9,5	60	160
1	10	54	145	1	7	29	98	1	6,9	4	22	7,5	9,5	44	140
2	10	44	110	2	7	29	98	2	6,9	4	18	7,5	9,5	40	100
10	7	22	48	10	5	14	55	5	6	3,5	12	6,6	6,5	25	50
20	5	15	34	20	3,5	10	37	10	4,4	3	8	6	4,5	18	44
30	4	12	27	30	2,9	8	30	20	3	2	6	4,6	3,5	12	30
50	3	10	20	50	2	6	22	30	2,5	1,6	4	3,8	2,9	10	24
100	2,3	6,5	15	100	1,5	4	15	50	1,9	1,2	3,2	3	2	7,8	19
150	1,8	5	12	150	1,2	3,5	12	100	1,3	0,8	2,2	2,5	1,5	6	13
200	1,5	4,5	10	200	1	3	10	150	1	0,7	2	2	1	4,5	10
300	1,2	3,5	8,5	300	0,9	2,5	8	200	0,9	0,6	1,8	1,8	0,9	3,7	9
400	1,1	3	7	400	0,7	2	7	300	0,7	0,5	1,5	1,5	0,8	3	7,5
500	0,92	2,8	6,5	500	0,65	1,8	6	400	0,6	0,4	1,2	1,2	0,7	2,5	6
600	0,85	2,5	5,5	600	0,6	1,6	5,6	500	0,55	0,37	1	1	0,65	2,3	5
700	0,8	2,2	5	700	0,55	1,5	5,2	600	0,5	0,35	0,95	0,8	0,6	2	4,8
800	0,75	2	4,8	800	0,5	1,4	4,9	700	0,45	0,3	0,9	0,75	0,55	1,9	4,5
900	0,7	1,9	4,5	900	0,48	1,3	4,5	800	0,4	0,27	0,8	0,7	0,5	1,8	4,2
1.000	0,65	1,85	4,3	1.000	0,46	1,2	4,3	900	0,38	0,26	0,7	0,6	0,4	1,6	3,3
1.500	0,5	1,5	3,5	1.500	0,36	1	3,4	1.000	0,3	0,21	0,5	0,5	0,3	1,2	2,7
2.000	0,45	1,3	2,9	2.000	0,3	0,85	2,8	1.500	0,28	0,18	0,4	0,45	0,25	1	2
2.500	0,4	1,1	2,5	2.500	0,26	0,7	2,5	2.000	0,25	0,14	0,35	0,4	0,20	0,85	1,8
3.000	0,35	1		3.000	0,24	0,6	2	2.500	0,2	0,13	0,3	0,35	0,18	0,7	
4.000	0,3	0,85		4.000	0,2	0,5		3.000		0,12	0,24	0,3	0,15	0,65	
5.000	0,25	0,75		5.000	0,18	0,4		4.000		0,1	0,21	0,25	0,13	0,55	
6.000	0,2			6.000	0,16			5.000		0,095	0,19	0,20	0,12		
8.000	0,18			8.000	0,13			6.000		0,08	0,16	0,18	0,099		
10.000	0,15			10.000	0,12			8.000		0,07		0,16	0,088		
								10.000		0,06			0,075		
								12.000							



**RG CABLES MAX POWER (Watt)**

RG/U	MHz									
	10	50	100	200	400	1000	3000	5000	10000	
5, 5A, 5B, 6A, 6B	2000	800	550	350	230	125	60	40	22	
7	3700	1300	850	540	350	190	95	65	37	
8, 8A, 10A, 70, 213, 215	3700	1300	850	540	350	190	95	65	37	
9, 9A, 9B, 214	3700	1300	850	540	350	190	95	65	37	
11, 11A, 12, 12A, 13, 13A, 216	2500	1000	650	400	260	150	70	50	26	
14, 14A, 74, 74A, 217, 224, 293, 293A, 388	6000	2000	1200	800	480	260	120	85	50	
17, 17A, 18, 18A, 177, 218, 219, 295	18000	5400	3200	1900	1100	560	240	160	--	
19, 19A, 20, 20A, 147, 220, 221	25000	7500	4500	2700	1600	800	340	--	--	
21, 21A, 222	340	160	115	82	60	38	15	--	--	
22, 22B, 111, 111A	1700	650	430	280	190	110	50	38	20	
29	1150	480	340	230	160	95	50	35	18	
34, 34A, 34B	7300	2700	1700	1050	680	380	140	80	--	
35, 35A, 35B, 164	15000	5800	3800	2500	1650	950	370	210	--	
54, 54A	1750	700	470	310	210	120	60	40	21	
55, 55A, 55B, 223	800	310	205	137	90	53	28	20	10	
57, 57A, 130, 131, 294, 294A	3400	1300	825	540	360	210	90	50	--	
58, 58B	730	280	180	125	85	50	25	17	--	
58A, 58C	650	255	170	110	75	44	22	15	--	
59, 59A, 59B	1300	480	310	200	135	77	40	27	15	
62, 62A, 71, 71A, 71B	1300	480	310	200	135	77	40	27	15	
62B	1150	420	280	180	120	69	35	25	14	
63, 63B, 79, 79B	3000	1050	680	490	340	200	90	51	28	
72, 125	2300	920	620	430	280	170	65	45	--	
87A, 115, 115A, 116, 165, 166, 225, 227, 393, 397	25000	9500	6300	4300	2800	1700	880	620	350	
94	25000	9500	6300	4300	2800	1700	880	620	350	
94A, 228	46000	17500	11500	7500	5000	2900	1500	1000	600	
108, 108A	340	145	100	70	50	30	15	--	--	
114, 114A	1150	480	340	230	160	95	50	35	18	
117, 117A, 118, 211, 211A, 228, 228A	101000	38000	25000	16000	10000	5800	2900	1950	--	
119, 120	35000	13500	9000	6000	4000	2300	1200	850	490	
122	540	205	140	90	60	35	18	12	--	
140, 141, 141A, 142, 142B, 159, 302, 303, 400, 402	9000	3500	2400	1600	1100	650	350	245	140	
143, 143A, 304, 401	11500	4600	3200	2100	1450	870	460	330	190	
144	25000	9500	6300	4300	2800	1700	880	620	350	
161, 179, 179A, 179B, 187, 187A	1600	780	570	420	310	200	110	76	41	
174, 174A	170	72	50	36	25	16	--	--	--	
178, 178A, 178B, 198, 198A, 403, 404	710	340	240	170	123	78	41	28	14	
180, 180A, 180B, 195, 195A	2500	1100	800	570	400	250	135	93	50	
183	14000	6000	4400	3000	2100	1300	670	470	--	
188, 188A, 318	1250	600	450	330	240	160	80	57	30	
197, 232	18000	8100	5800	4000	2800	1700	820	600	--	
198	6800	3100	2200	1600	1100	650	360	270	180	

**RG CABLES MAX POWER (Watt)**

RG/U	MHz									
	10	50	100	200	400	1000	3000	5000	10000	
199	15000	7000	5000	3400	2400	1400	740	540	--	
200	42000	18000	13000	8700	5800	3300	1700	--	--	
209, 281	101000	38000	25000	16000	10000	5800	2900	1950	1050	
231, 331, 210	8500	3300	2300	1600	1100	620	310	220	140	
233, 240	48000	21000	15000	10000	6800	3900	2100	--	--	
234, 242	130000	53000	37000	24000	17000	9200	--	--	--	
235	25000	9500	6300	4300	2800	1700	880	620	350	
236, 237	7500	3700	2600	1800	1200	730	380	280	180	
244, 245	6000	2800	1900	1300	920	580	300	220	150	
246, 247	13000	5900	4200	2900	2100	1200	630	450	--	
248, 249	38000	17000	12000	8000	5500	3200	1700	--	--	
250, 251	100000	42000	28000	19000	13000	7200	--	--	--	
252, 253	8000	3500	2500	1800	1200	750	380	280	180	
254, 255	19000	8000	5700	4000	2800	1700	850	600	--	
256	36000	16000	11000	7700	5400	3400	1800	1200	--	
257, 258	50000	21000	15000	10000	7000	4100	2000	--	--	
259	8700	3800	2600	1800	1300	800	430	320	200	
263	65000	26000	17000	12000	8000	4800	2600	1900	1300	
265, 267, 270, 270A, 270B, 319, 319A	48000	21000	14000	10000	7000	4200	2100	--	--	
268, 366	7800	3300	2200	1600	1000	570	280	190	120	
269, 269A, 297, 318	22000	9000	6200	4300	3000	1900	1000	700	--	
279	4500	1900	1350	950	660	410	230	160	91	
280	46000	17500	11500	7500	5000	2900	1500	1000	600	
282	1200	600	450	330	240	160	80	56	30	
284, 284A	16000	6200	4300	3000	2100	1300	700	530	--	
285A	--	--	--	--	--	--	--	--	--	
286, 292	35000	15000	10000	7000	4800	2900	1700	--	--	
288, 321, 322	90000	38000	26000	18000	13000	7200	--	--	--	
289	63000	27000	19000	13000	9100	5000	--	--	--	
306, 306A, 336	15000	5500	3700	2500	1700	1000	480	300	--	
307, 307A	1300	470	310	200	130	78	39	28	15	
323, 324, 332, 333, 376	17000	6900	4700	3200	2100	1200	550	380	--	
325	3800	1300	840	540	340	190	92	64	37	
326	11000	3400	2000	1200	720	380	170	115	--	
327	23500	6900	4000	2350	1400	700	300	--	--	
334, 335	6600	2700	1800	1300	860	510	280	190	110	
360	12000	5100	3500	2300	1600	900	450	290	--	
367	250000	110000	75000	51000	35000	21000	--	--	--	
369, 370	4300	1900	1400	960	670	400	220	160	110	
377	16000	6800	4700	3300	2300	1400	780	580	350	
385	70000	26000	16000	11000	7000	4200	2300	1700	1100	
389, 189	20000	5400	3100	2100	1500	800	400	--	--	

		Others Informations
Network name /Television/Radio		
TX Station name and/or ID number		
Site name / address		
Station Type (Radio/ TV)		
Site Longitude (ddd°pp'ss'")		
Site Latitude (ddd°/pp'/ss'")		
Ground level a.s.l.(m)		
Antenna system height a.g.l.(m)		
Transmitter power (Watt)		
Transmitter Brand and Model		
Used band :FM/VHF Band I/VHF Band III/UHF/ MMDS/etc		
Used channel or fequency		
Analog used Standard: PAL/NTSC/SECAM/etc		
Digital used Standard:DVBT/DVBT2/ATSC/ ATSC2/ ISDB/ISDB-Tb/ DAB/etc.		
Country		
Dual-Cast and systems: Yes/No, Systems		
Used antenna system height a.g.l.(m)		
Anten. feed cable type: transmitter to antenna		
Anten. feed cable lenght: transmitter to antenna (m)		
Antenna Brand		
Power supply equipments:110/220/380/etc		
Type power supply: Monophase / Threephase		
Frequency power supply: 50/60 Hz		

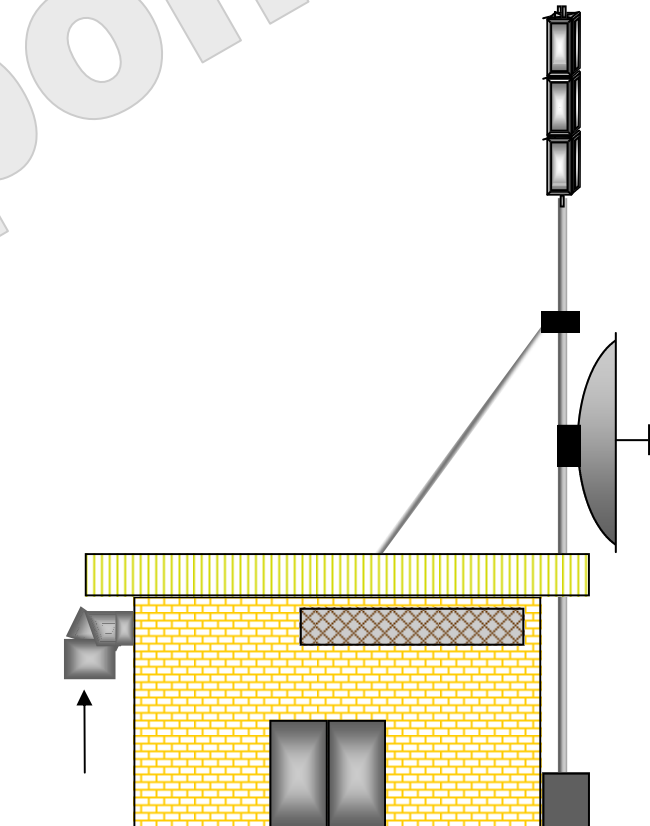





DIPOLE ANTENNA  
FM(Radio), TV VHF I, III BAND



YAGI ANTENNA  
FM(Radio), TV VHF I, III BAND



LOG ANTENNA  
FM, TV VHF I, III, UHF BAND



PANEL ANTENNA  
FM, TV VHF III Band



YAGI ANTENNA  
TV VHF / UHF BAND



PANEL ANTENNA SYSTEM  
TV UHF BAND



TURNSTYLE ANTENNA  
TV UHF BAND

Telecomponents

www.telecomponents.com